

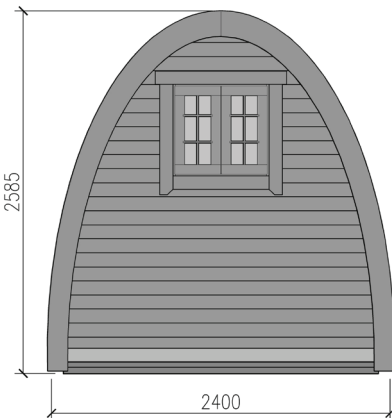

Camping Pod

4 M

health, beauty, peace of mind

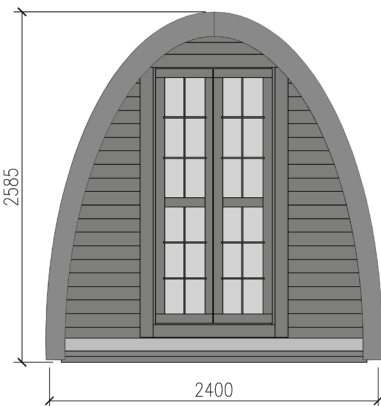
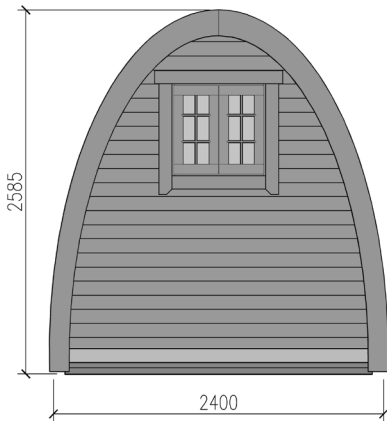
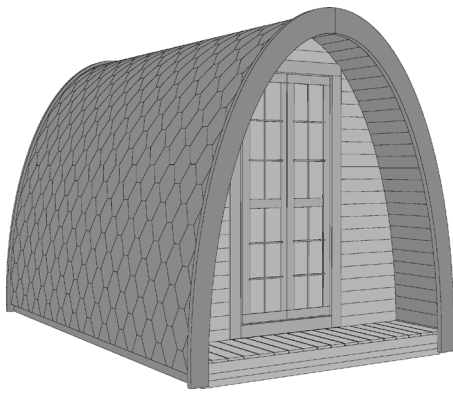

Specifications



Wood	Spruce
Shape	Pod
Inside area, m ²	7,5
Total height, m	2,58
Size of terrace, mm	2324x600
External dimensions (WxD), mm	2400x4000
Number of windows	1
Number of opening windows	1
Weight, kg	1300
Group of persons	2-4
Size of windows, mm	678x714
Size of doors, mm	1004x1920

STANDARD SET

- Pod made from spruce wood;
- Roof covered with bitumen shingles;
- Double doors with a lock and the double glass windows;
- Opening window in the back wall.

OPTIONS

- A color of roof shingles: red, black, green;

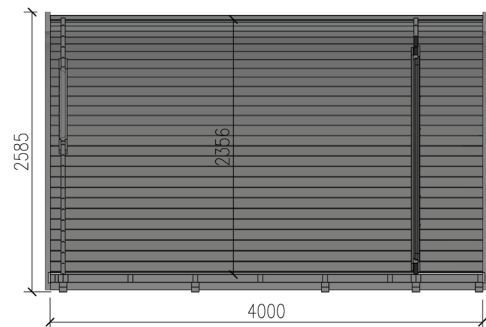
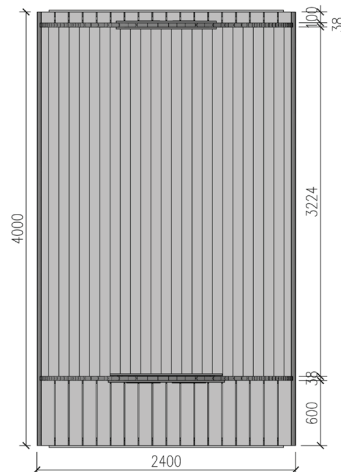

Windows and doors



Window's size is 678x714 mm, door's size is 1004x1920 mm. Double glass units are used; they windows ensure lower heat transfer to the outside, a lot of light coming inside, and long usage time.

Roof shingles



BITUMEN SHINGLES

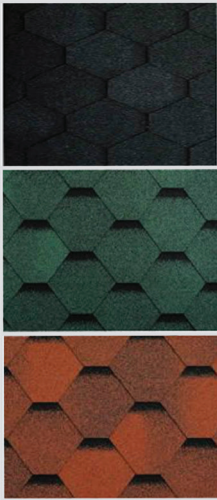

6 layer bitumen shingles are made from a durable and highly resistant fiber glass base coated with the polymer-reinforced bitumen mix which includes a high quality bitumen and an aggregate. The top layer of the shingles is covered with mineral granules ensuring the protection from UV as well as from other weather conditions. The granules are painted using a thermal method, which means that a pigment is burned-in into the surface of granules and this guarantees a long durability of the color. The bottom of the shingles is an adhesive polymer-reinforced bitumen layer protected with an easily removable silicon membrane. Due to the sun heat the overlapped tiles on the top stick to each other thus forming a double hydro-insulating layer which guarantees an excellent leak resistance of the roof. A color of the roof shingles can be chosen from black, green or red. A warranty term for the shingles is 15 years!

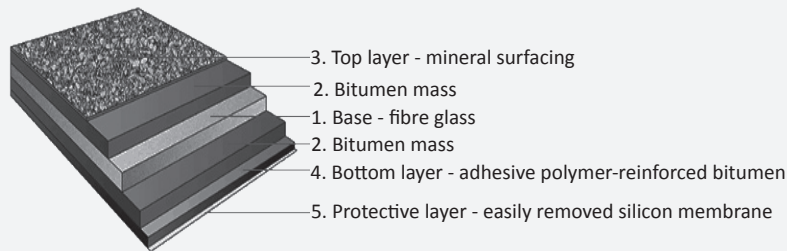

Type of wood



SPRUCE



We mainly use Nordic spruce, which comes from Scandinavia. The light, golden-white softwood radiates a friendly warmth. Every single board used for our Camping Pod has its own individual character and history, and this makes our Camping Pod a real natural and unique product.

Transportation

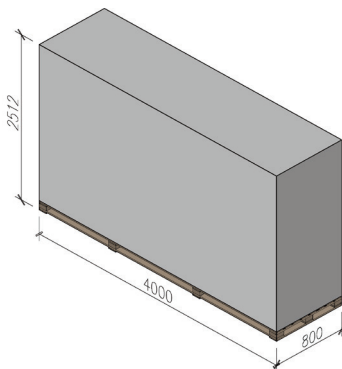

Not assembled camping pod

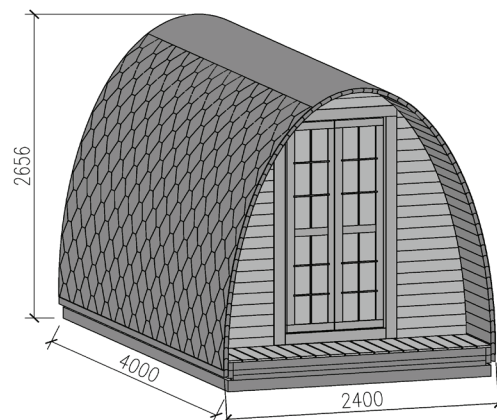

Assembled camping pod

The Camping Pod is delivered to a customer fully assembled or not-assembled (packed on a pallet (KIT)), but fully complete, with detailed assembly instructions and drawings. Two people can easily assemble camping pod in 7 hours.

Weight is **1300 kg**.

Foundation

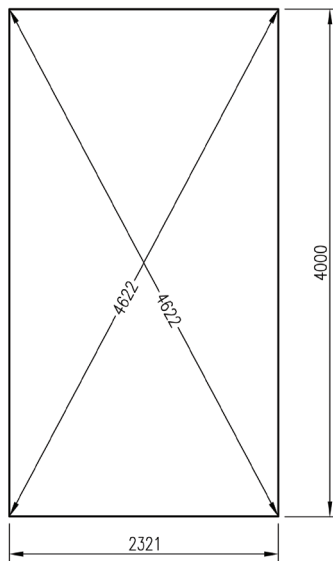

It is very important to have a proper foundation for your camping pod. Therefore we recommend making the foundation according to the sketches here.

First of all, foundation must be prepared according to the landscape and ground conditions. Consult a qualified builder or an engineer to prepare a proper foundation, which fits your location. Make sure to complete the site preparation and the foundation before unpacking and assembling the camping pod.

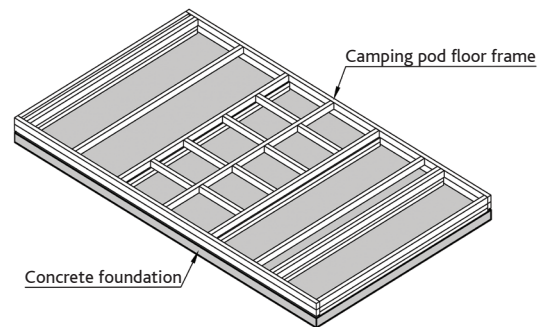

Maintenance



As wood is a natural material, it can change through time. Cracks of various sizes, changes of the color as well as of a structure of the wood are not the errors, but a feature of wood.

Natural wood (not impregnated) becomes grayish after having been left untouched for a while. Later it can turn blue and get covered with the mold. Therefore, you should immediately impregnate the wood to protect the products.

We strongly recommend that you impregnate the door and windows with a wood impregnation agent both the inside and outside of them, because the doors and windows can become twisted otherwise. In general, we

recommend consulting a specialist regarding the paints suitable for an unprocessed softwood and follow the instructions of paints' manufacturers. Proper painting of the camping pod will extend its lifetime. Besides that, we suggest you thoroughly inspecting the pod every six months and checking if it needs re-painting or else.

It's NOT advisable to paint the camping pod walls before assembling it – this is best done when the camping pod has been already assembled and when the weather is fine. However, if you wish to paint some parts in different colors, this should be done before the camping pod is assembled.