



Regulation and measuring device IRIS

Construction

The IRIS is composed of regulation plates, regulating nut or handle (size 80) and regulation scale plus manometer connections and casing.

The casing and regulation plates are made of hot-galvanized steel other components of plastic. The joining collars are supplied with rubber sealing gasket.

Use

IRIS is an ideal solution for the exact and quick air flow measuring and regulation.

Installation

The IRIS damper is secured to the ducting with rivets. For vertical mounting ensure the weight of the interconnecting ductwork is fully supported. Refer to page 5 for recommended safety distances.



Dimensions

Size 80

Sizes 100...800

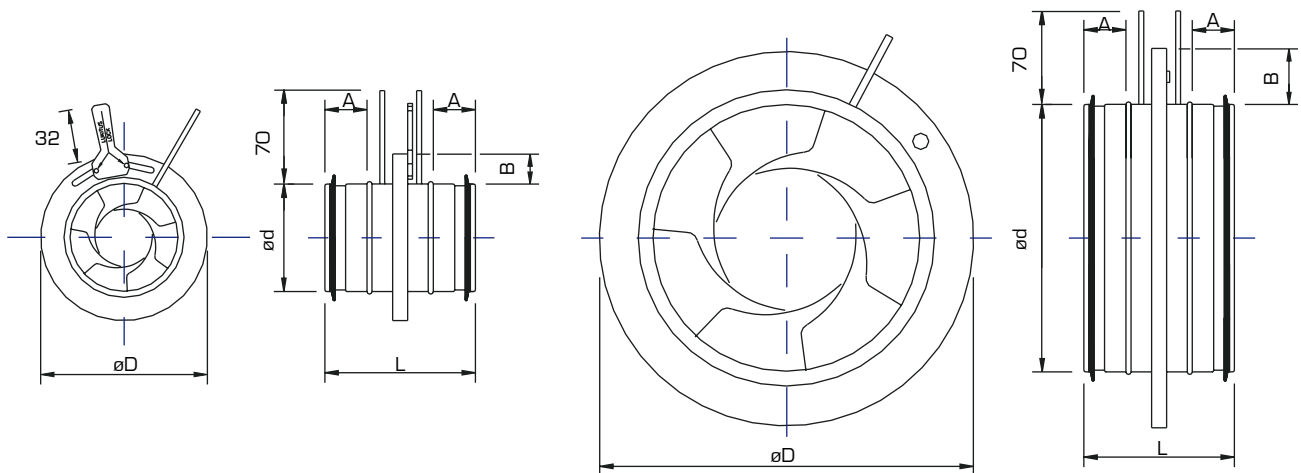

Size	ød	øD	L	A	B	Weight kg
80	79	125	120	35	22	0,5
100	99	165	110	30	32	0,5
125	124	188	110	30	32	0,7
150	149	230	110	30	40	0,9
160	159	230	110	30	35	0,9
200	199	285	110	30	42	1,4

Size	ød	øD	L	A	B	Weight kg
250	249	335	132	40	42	2,1
315	314	410	132	40	47	3,5
400	398	525	155	50	62	6,4
500	498	655	170	50	77	9,6
630	628	815	170	50	92	15,6
800	798	1015	270	100	107	25,0

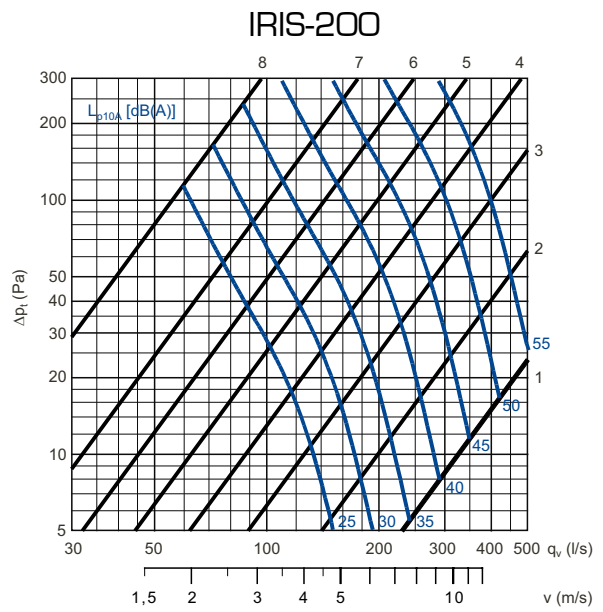
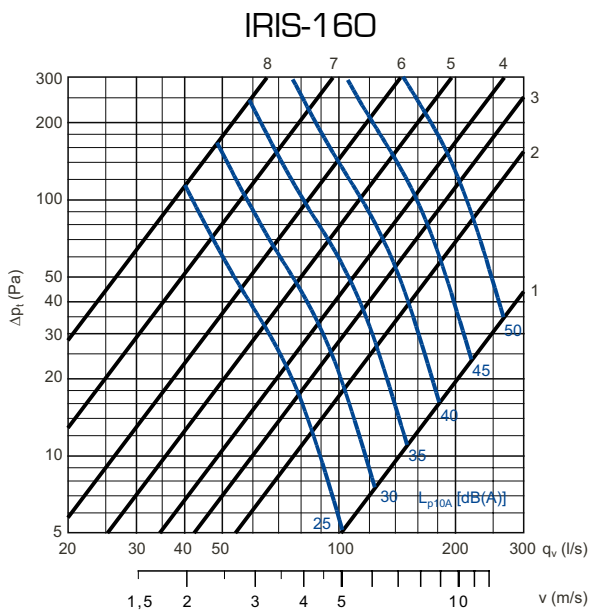
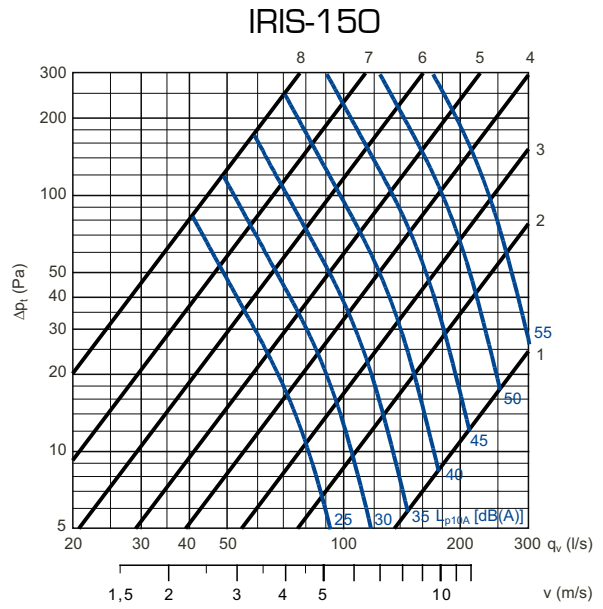
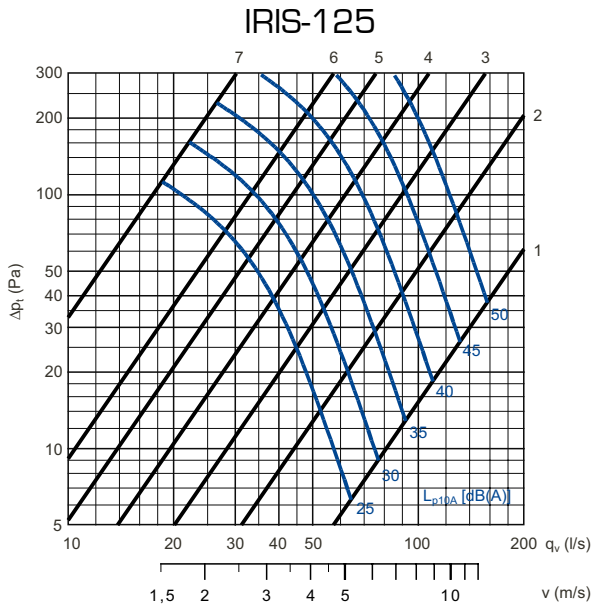
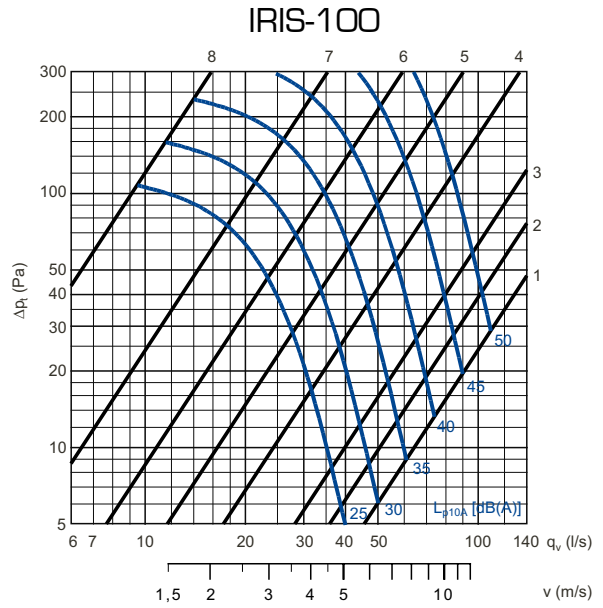
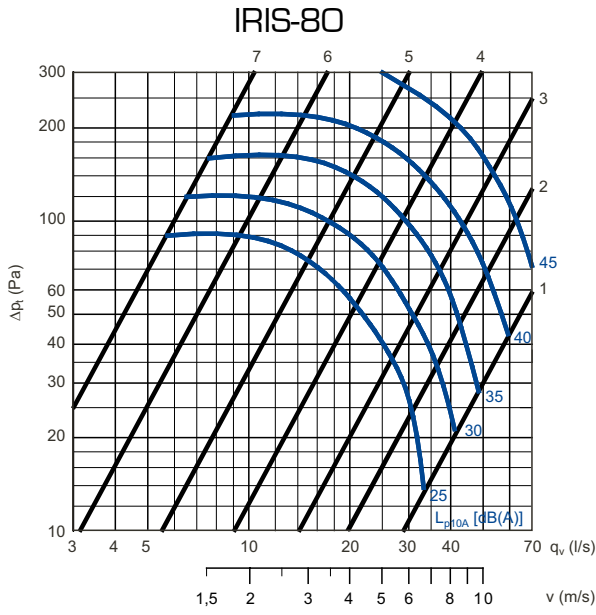

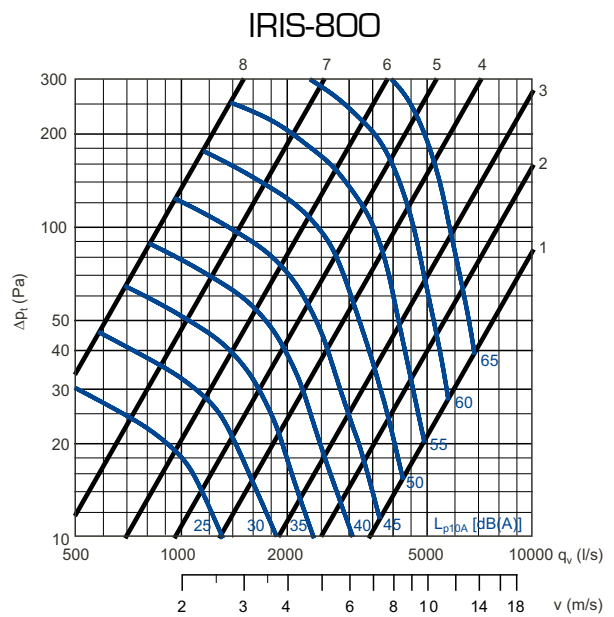
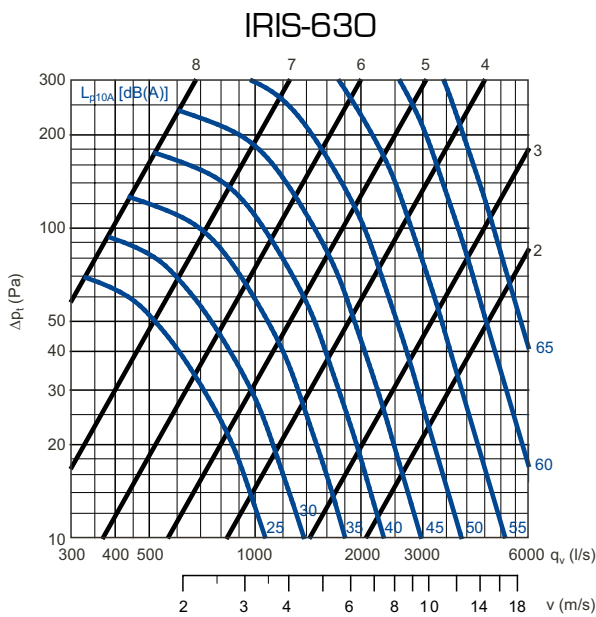
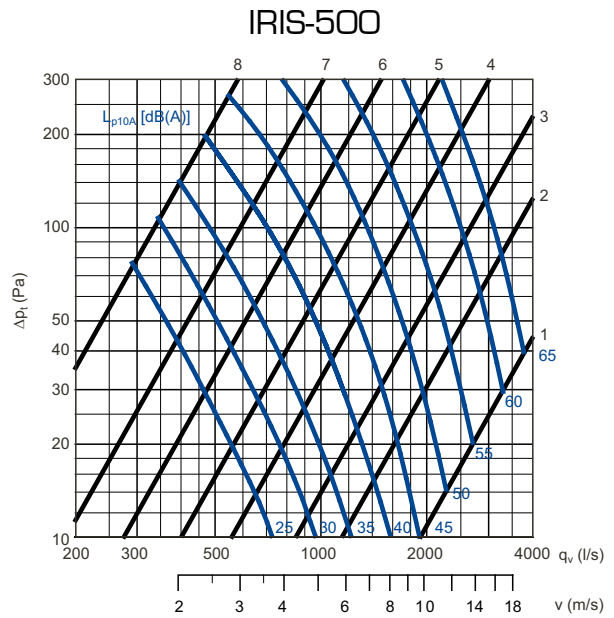
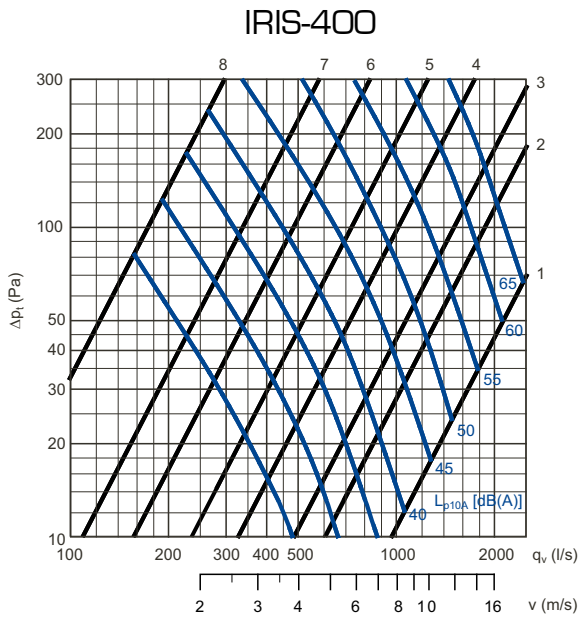
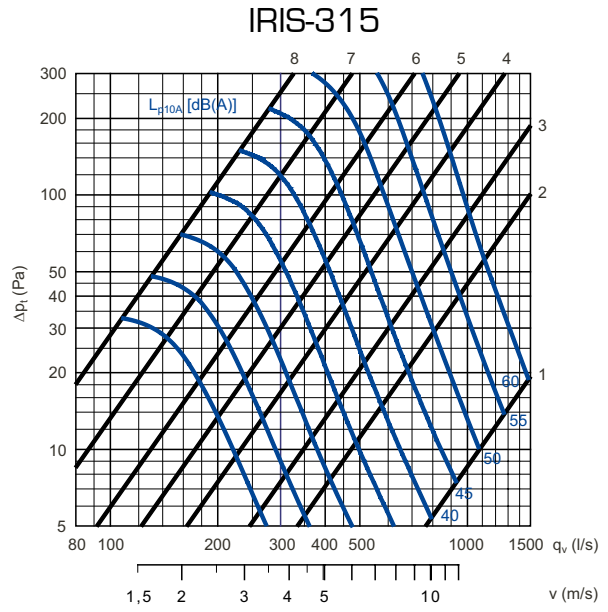
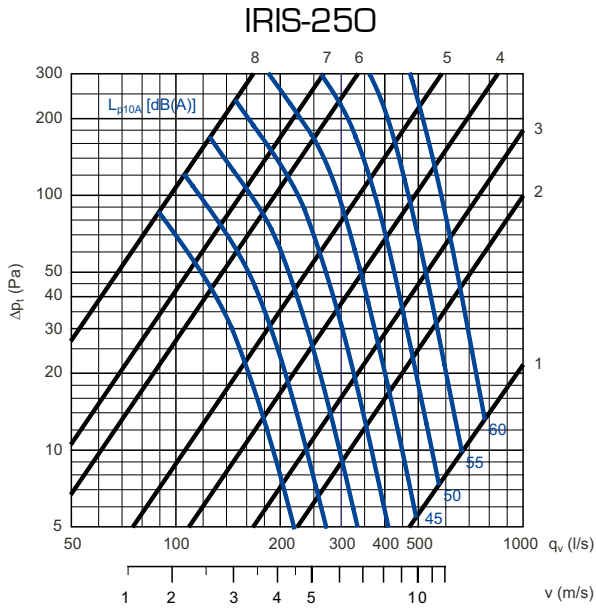

Regulation and measuring device IRIS

Material specification

Product component	Material
Casing, blades	Hot galvanized steel
Regulation mechanism	Polyacetal
Stickers, window cover	PVC plastic
Veloduct-sealing	EPDM rubber
Measuring tap	TRP plastic

Safety distances

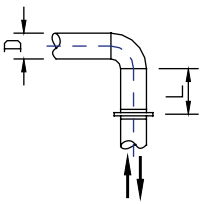
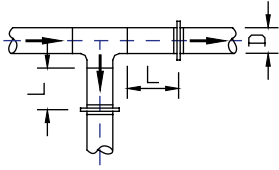
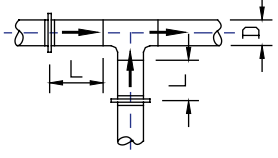
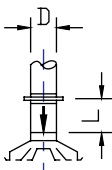
Type of flow disturbance	The required safety distance L	
	$m_2 = \pm 7\%$	$m_2 = \pm 10\%$
	$\geq 1 D$	$\geq 1 D$
	$\geq 4 D$	$\geq 2 D$
	$\geq 2 D$	$\geq 2 D$
	$\geq 2 D$	$\geq 2 D$

Accuracy of calibration during disturbancefree air flow: $\pm 5\%$.

To ensure the functioning of the inlet air diffuser.

Regulation and measurement of air flow

The regulation plates form a virtually ideal measuring orifice which enables an easy and reliable measurement of the air flow.

To determine the air flow, measure the pressure difference Δp_m at the manometer connections and check the corresponding air flow from the regulation chart.

The chart is shown on the damper casing and in the separate information for air flow regulation and measurement (the selection diagrams do not serve the air flow measurement).

Air flow is regulated by the regulating nut or handle.

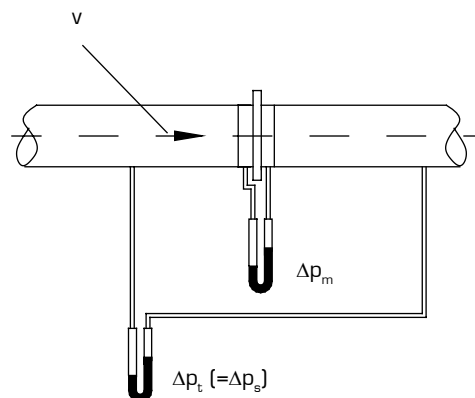

Regulation and measuring device IRIS

Sound characteristics

IRIS	CORRECTION K_{oct} (dB)							
	Medium frequency by octave band (Hz)							
	63	125	250	500	1000	2000	4000	8000
80	10	16	12	9	5	-1	-6	-23
100	25	21	16	9	4	-6	-12	-25
125	17	17	13	7	1	-4	-6	-17
150	21	20	14	8	0	-6	-16	-29
160	19	18	14	6	-1	-6	-13	-25
200	20	17	12	5	-2	-5	-14	-26
250	16	12	8	3	1	-4	-17	-32
315	24	12	5	0	1	-2	-13	-27
400	15	9	6	2	-1	-4	-9	-13
500	14	7	4	1	-1	-4	-8	-11
630	15	7	3	2	-1	-5	-9	-11
800	9	5	3	3	-1	-6	-10	-13
Tol.±	6	3	2	2	2	2	2	3

The sound power levels of the duct for every octave band are obtained by adding the corrections K_{oct} of octave bands (see table above) to the total sound pressure level L_{p10A} dB(A) according to the following formula:

$$L_{Woct} = L_{p10A} + K_{oct}$$

Correction K_{oct} is the average in the range of use of the IRIS regulation and measuring device.

Cleaning

